

Butterfly valve series

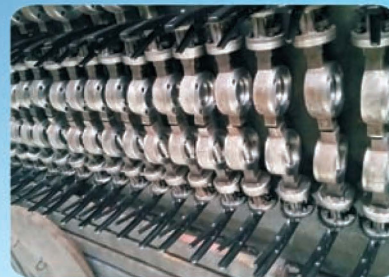

Use

Butterfly valves are widely used in urban construction, petrochemical, metallurgy, electric power industry medium channels to cut off or regulate medium flows.

Features

The butterfly valve is the best open and closure device in the pipeline and leads the trend of open and closure device, its main features are quick open and closure, can easily achieve by rotating 90° enables automated remote control; simple structure, small size, light weight, small installation space; metal seated and soft seated structure can be used in a variety of conditions, good sealing performance, long service life; fire safe design; full open condition enables small flow resistance, and half open condition, allows flexible flow control; low operating torque valve, simple and quick operation.

1. Concentric

The butterfly valve seal seat section or the sub-line of plate thickness direction and stem circling centre is relatively eccentric (length A), makes the valve plate gradually become eccentric from the seat sealing surface at the opening process to 20° ~ 25° rotation, and enables less mechanical wear and extrusion, thus improves the sealing performance of a butterfly valve. This sealing design relies on flexible eccentricity from the extrusion between the valve plate and seat, so the single eccentric structure applies only to soft butterfly valve seal.

2. Double eccentric

On the basis of the single-eccentric butterfly valve, the plate circling centre and the channel centerline is relatively bias (length B) that forms cam effect at the opening process of the butterfly valve, and enables valve plate sealing faster eccentricity when plate turns to 8°~12°, valve plate completely separates from the sealing surface. This design greatly lowers the mechanical wear and tear between two sealing surfaces, thus improves the sealing performance.

3. Triple eccentric

On the basis of the single-eccentric butterfly valve, the plate circling centre and the channel centerline is relatively bias (length B) that forms eccentric angle (angle β) at the opening process of the butterfly valve, and enables valve plate sealing complete eccentricity and contact at closure. This unique eccentricity structure fully adopts cam effect and enables complete elimination of mechanical wear and tear between two sealing surfaces and reduce the possibility of leakage. Turning extrusion sealing into torque sealing by regulating actuator torque valve, achieves sealing pressure ratio regulation, thus improves the sealing performance and increase service lifetime of triple eccentric butterfly valve.

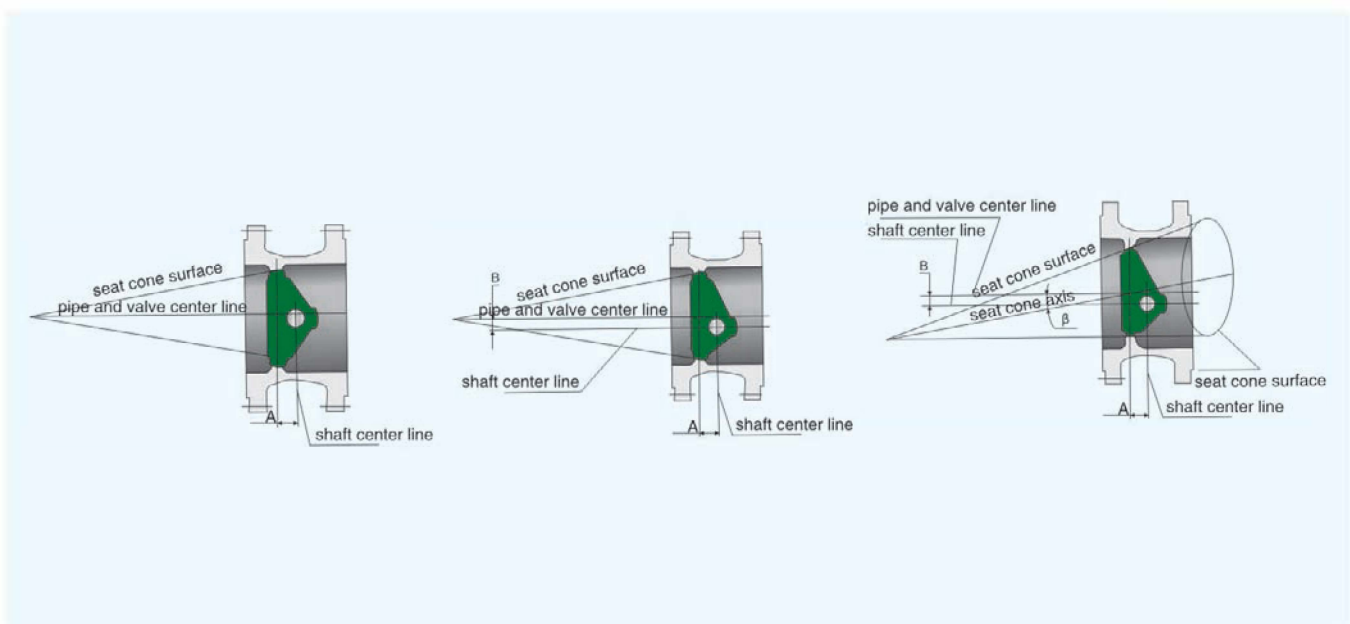

Vice-sealed a variety of structures

1、Triple eccentric



1. Three eccentric metal seal



2. Eccentric three-layer composite metal sealing



3. Eccentric three-layer composite metal seal

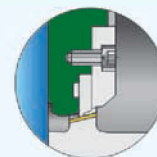

4. Three eccentric metal sealing

2、Double eccentric



5. Rubber seal (seat on disc)

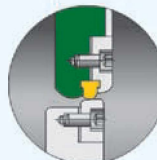

6. Rubber seal (which is floating valve seat)

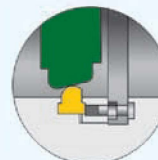

7. Rubber seal



8. PTFE seal

3、Concentric

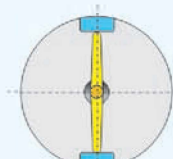

9. Metal seals

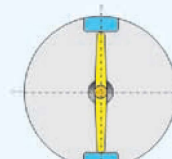

10. Sealing the soft (rubber and PTFE)

4、High-performance metal seated structure

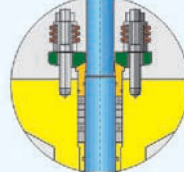
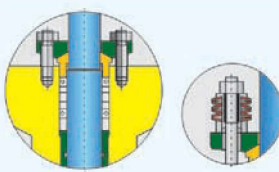

The option-live loading

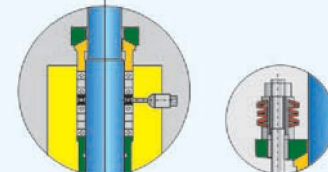

Stem seal

This is a kind of improved high-performance butterfly valve. The valve includes parts of body, plate, the circular groove or beveled edges, stem and seat. At the surrounding areas of the plate there's at least one outer ring edge to provide better clean-up and reduce wear and tear. Stem centre lines with the plate rotating center, but slightly eccentric from valve center line.

Provides predictable and constant packing compression for more than 5000 cycles before adjustment or re-packing double packing with leak-off monitoring/purge port. Two sets of packing rings, precompressed to 27 MPa (graphite). A ring and leak-off connection allows removal of leakage, if any, from bottom packing set.

Standard stem-seal

Provides predictable and constant packing compression for more than 5000 cycles before adjustment or re-packing.

- (1) Short and narrow packing ring structure;
- (2) Large compression load required; graphite rings precompressed to 27MPa for effectiveness of all rings. Gland torque must be maintained after installation and in service to levels shown in manuals
- (3) Higher finish ($3.2 \mu\text{m}$) of packing chamber and stem surface ($0.8 \mu\text{m}$) to assure a longer service life.
- (4) Stem bearing stem to assure concentric stem rotation, allowing stem packing to provide maximum sealing effectiveness.

5、Fugitive emission stem seals

- (1) Full-guided stem seal Stem bearings in body and gland followers prevent wobbling and packing leakage due to side thrust on stem
- (2) Precompressed packing rings to 27MPa;
- (3) higher finish ($3.2 \mu\text{m}$) of packing chamber and stem ($0.8 \mu\text{m}$), to ensure a longer cycle life.
- (4) live-loading. Provides constant packing compression and is essential for this packing arrangement.
- (5) two-piece flanged gland with spherical mating surfaces to assure an even packing load.
- (6) two O-rings in gland follower provide additional stem seal protection to assure tightness.

Class 150 Concentric design, rubber seat, wafer type

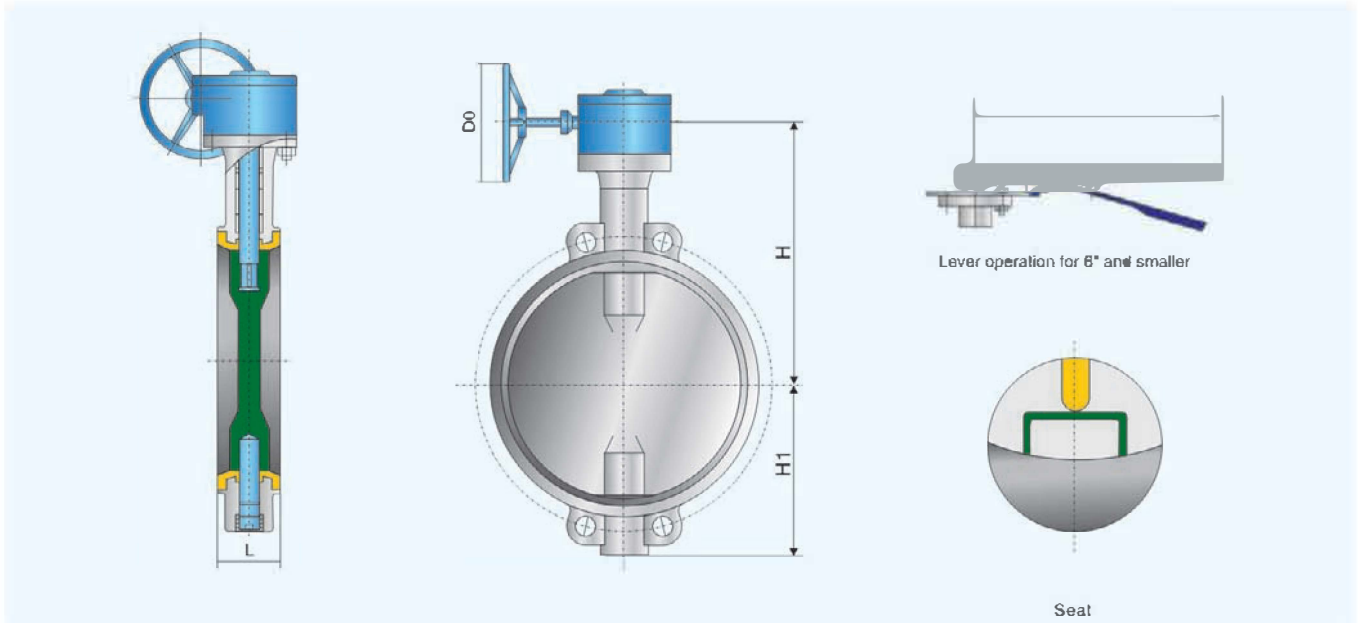

Parts List

Part Name	Material	Part Name	Material
Body	ASTM A216 WCB	Stem	ASTM A276 410
Seat	NBR	Thrust Washer	304+PTFE
Disc	WCB	O-Ring	NBR

Note:

Lever operations for $\leq 6"$
 Worm Gear for $> 6"$
 Flange End: ASME B16.5, ASME B16.47, ANSI B16.1
 Face to Face dimension: API 609 & MSS SP-68
 For other ends, please state in the order.
 Available for other material such as cast iron, ductile iron, stainless steel etc.

Dimensions & Weights

NPS(in)	L(mm)	H1(mm)	H(mm)	D0(mm)	L0(mm)	WT(Kg)	
						Wafer	Lug
2	43	74	180	160	200	10	11
2-1/2	46	79	196	160	200	10	12
3	46	85	205	160	200	11	13
4	52	101	215	160	200	12	15
5	56	112	230	160	240	14	18
6	56	125	245	240	240	16	19
8	60	160	280	240	240	20	24
10	68	192	315	240	280	28	34
12	78	242	355	310	280	39	46
14	78	277	410	310	-	67	77
16	102	302	425	310	-	89	108
18	114	341	462	310	-	109	125
20	127	366	495	310	-	128	168
24	154	424	586	310	-	230	280
30	165	520	690	400	-	284	312
36	200	590	738	400	-	368	442
42	251	656	838	400	-	713	856
48	276	720	945	640	-	864	1010

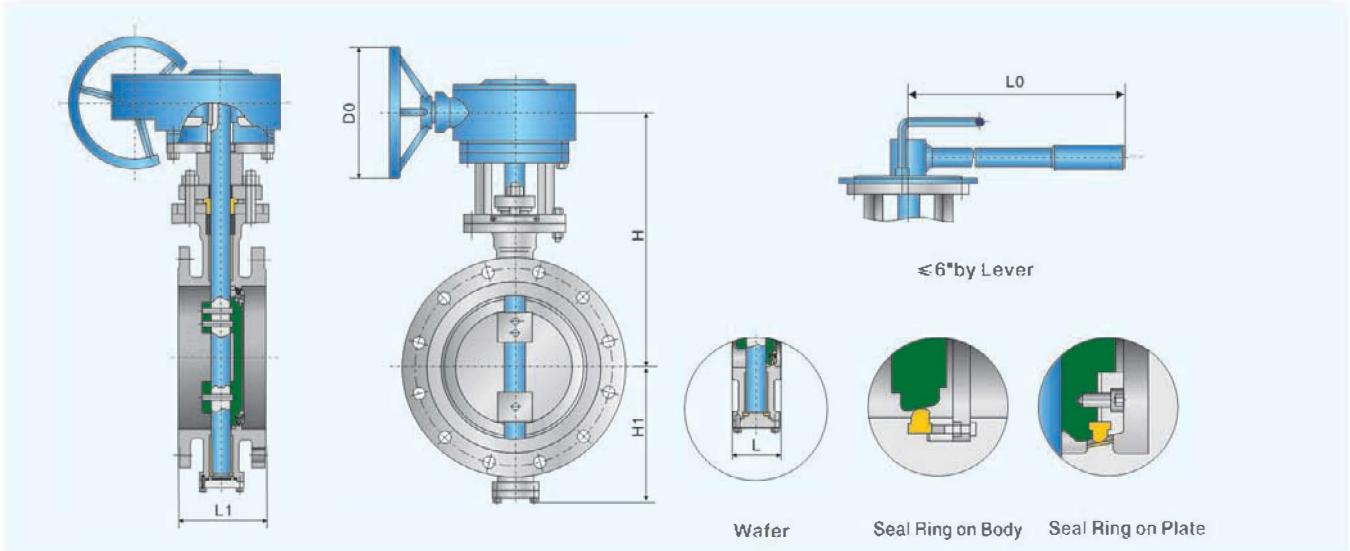

Parts List

Part Name	Material	Part Name	Material
Body	ASTM A216 Gr.WCB	Gland	ASTM A105
Seat	NBR	Thrust Washer	304+PTFE
Disc	ASTM A216 WCB	Packing Bushing	ASTM A276 410
Stem	ASTM A276 410	Packing	Flexible Graphite

Note:

Lever operations for $\leq 6"$
 Worm Gear for $> 6"$
 Flange End: ASME B16.5, ASME B16.47, ANSI B16.1
 Face to Face dimension: API 609 & MSS SP-68
 For other ends, please state in the order.
 Available for other material such as cast iron, ductile iron, stainless steel etc.

Dimensions & Weights

NPS(in)	L(mm)	L1(mm)	H1(mm)	H(mm)	D0(mm)	L0(mm)	WT(Kg)
2	43	108	110	135	-	150	20
3	48	114	125	155	-	180	29
4	54	127	147	162	-	200	33
6	57	140	166	240	-	300	74
8	64	152	215	375	180	-	86
10	71	165	238	396	180	-	142
12	81	178	283	446	180	-	167
14	92	190	302	472	315	-	218
16	102	216	338	555	350	-	275
18	114	222	381	605	400	-	315
20	127	229	408	638	480	-	395
24	154	267	495	738	480	-	580
28	165	292	561	976	480	-	657
30	190	318	590	1016	610	-	717
32	190	318	650	1160	610	-	880
36	203	330	700	1205	480	-	1042
40	216	410	750	1294	480	-	1760
42	229	410	780	1350	480	-	1820
48	254	470	892	1523	480	-	2660

Double eccentric, PTFE seat butterfly valve



Features

Double eccentric construction reduces friction of between the plate and the seat, less torque operation value and longer service life. Special spherical design for plate and seat Bi-directional seal, zero leakage Low valve operating torque.

Technical Specification

Working Pressure: CLASS 150~CLASS 300
 Working Temperature: PTFE Seat: -46~+160°C
 R-PTFE Seat: -46~+180°C
 PPL Seat: -100~+260°C
 Design and manufacture standard: API 609
 Flanged End: ASME B16.5, ASME B16.47, ANSI B16.1
 Face-to-Face dimension: API 609 & MSS SP-68
 Test and Inspection: API 598
 Note: for other ends, please state in the order

Opening Torque Value

NPS(mm)	Max. Differential Pressure ΔP (MPa)	
	2.0	5.0
2	110	252
2-1/2	144	360
3	156	410
4	312	550
5	492	960
6	624	1000
8	758	1400
10	1400	2160
12	2184	4500
14	3000	5400
16	3600	7200
18	4870	11160
20	8760	12800
24	9600	27680
28	14500	-
32	18500	-
36	25200	-
40	25000	-

Flow Features

Flow curve chart

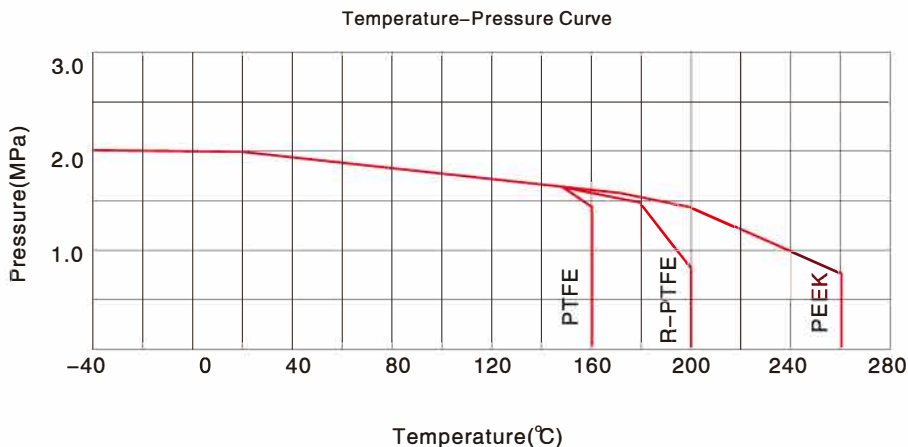

Flow rate

Cv value is calculated on the standard condition while the pressure on both sides falls below 0.007MPa

DN(mm)	2	2-1/2	3	4	5	6
Cv	102	102	242	423	423	1160
DN(mm)	8	10	12	14	16	18
Cv	2016	3066	4568	6325	8152	11023
DN(mm)	20	24	28	32	36	40
Cv	13780	20486	31586	35612	47860	71460

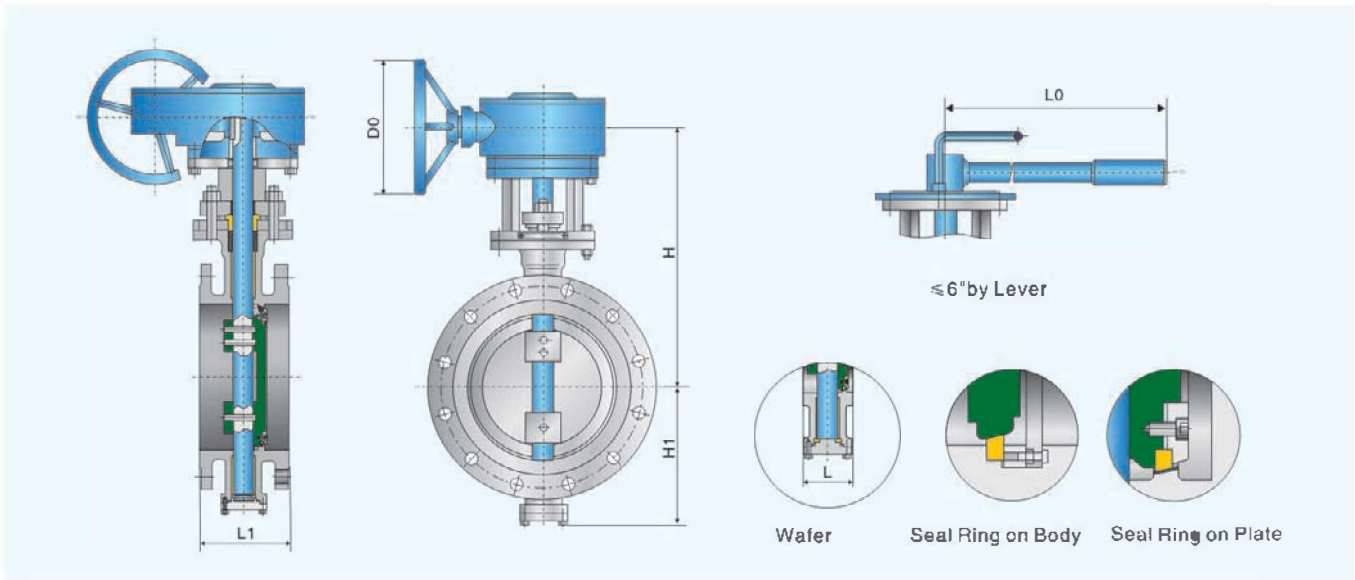

Parts List

Part Name	Material	Part Name	Material
Body	ASTM A216 Gr.WCB	Gland	ASTM A105
Seat	PTFE	Thrust Washer	304+PTFE
Disc	ASTM A216 Gr.WCB	Packing Bushing	ASTM A276 410
Stem	ASTM A276 410	Packing	PTFE

Note:

Lever operator for ≤6"
 Lever-to-Face dimension: API 609 & MSS SP-68
 Flanged End: ASME B16.5, ASME B16.47, ANSI B16.1
 Note: For other ends, please state in the order
 Available for other material such as cast iron, ductile iron, stainless steel etc.

Dimensions & Weights

NPS(in)	L(mm)	L1(mm)	H1(mm)	H(mm)	D0(mm)	L0(mm)	WT(Kg)		
							Wafer	Lug	Flange(Short Pattern)
2	43	108	110	135	-	150	10	11	20
3	48	114	125	155	-	180	11	13	29
4	54	127	147	162	-	200	13	16	33
6	57	140	166	240	-	300	26	28	74
8	64	152	215	375	180	-	36	43	86
10	71	165	238	396	180	-	53	64	142
12	81	178	283	446	180	-	74	86	167
14	92	190	302	472	315	-	110	127	218
16	102	216	338	555	350	-	138	159	275
18	114	222	381	605	400	-	180	211	315
20	127	229	408	638	480	-	196	225	395
24	154	267	495	738	480	-	400	462	580
28	165	292	561	976	480	-	560	655	657
30	190	318	590	1016	610	-	685	812	717
32	190	318	650	1160	610	-	726	868	880
36	203	330	700	1205	480	-	920	1056	1042
40	216	410	750	1294	480	-	1283	1470	1760
42	229	410	780	1350	480	-	1488	1723	1820
48	254	470	892	1523	480	-	1645	1895	2660

Triple eccentric, metal seat butterfly valve



Features

Triple eccentric design reduces the friction between plate and seat, and increases the valve service life. Plate and seat oblique cone design turns the compression seal into torque seal, achieves bi-directional seals. Metals and non-metallic compound seal ring combines the rigidity of the metal, the wear-resistance and flexibility of the soft seat, ensures reliable seal and greater performance. Low opening torque value

Technical Specification

Working Pressure: CLASS 150~CLASS 900
 Working Temperature:
 304 Seat: -73~+450°C
 316 Seat: -73~+450°C
 Special seat: -268~+650°C
 Design and manufacture standard: API 609
 Flanged End: ASME B16.5 & ASME B16.47
 Face-to-Face dimension: API 609 & MSS SP-68
 Test and Inspection: API 598
 Note: For other ends, please state in the order

Opening Torque Value

NPS(mm)	Max. Differential Pressure ΔP (MPa)	
	2.0	5.0
2	168	252
2-1/2	239	360
3	276	410
4	372	550
5	592	960
6	672	1000
8	938	1400
10	1450	2160
12	3000	4500
14	3600	5400
16	4870	7200
18	7440	11160
20	14630	12800
24	20760	27680
28	31764	-
32	38724	-
36	47860	-
40	75600	-

Flow Features

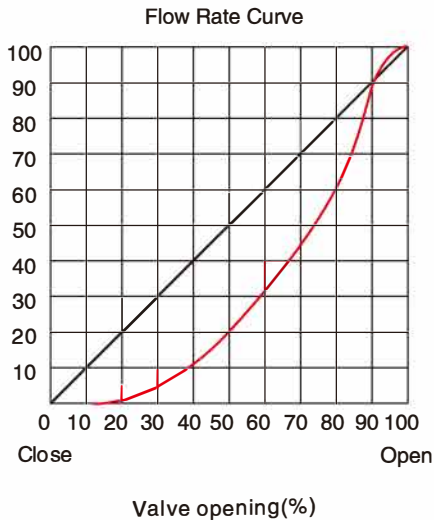

Triple eccentric design features

On the basis of double eccentric design, the centreline of the plate seal surface and seat centreline forms angle (γ° , and enables slight wedge effect when the plate contacts the flexible metal seat, and slight move and radial deformation of the seat ring along with the plate, average compression around the seat ring thus achieves complete sealing. This unique triple eccentric design fully applies Cam effect in the valve, greatly reduces the friction at the contact area, possibility of leakage and also the opening torque value, increases longer service life, achieves easy and convenient operation.

Flow rate

Cv value is calculated on the standard condition while the pressure on both sides falls below 0.007MPa

DN(mm)	2	2-1/2	3	4	5	6
Cv	102	102	242	423	423	1160
DN(mm)	8	10	12	14	16	18
Cv	2016	3066	4568	6325	8152	11023
DN(mm)	20	24	28	32	36	40
Cv	13780	20486	31586	35612	47860	71460

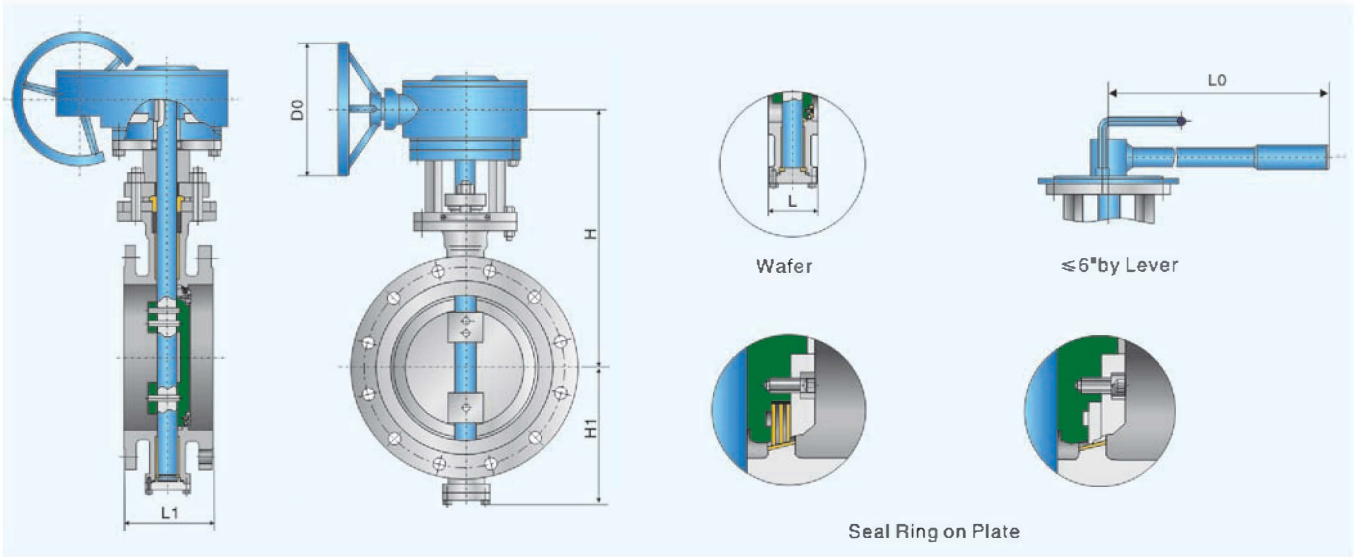

Main Parts and Materials

Parts	Material
Body	WCB, LCB, LCC, CF8, CF8M, CF3, CF3M
Seal Ring	304 / 316 / S31803 + Graphite / PTFE Laminated
Disc	WCB, LCB, LCC, CF8, CF8M, CF3, CF3M
Seal Surface	Cr13, 304, 316, Stellite or Integral on body
Stem	F6a, F304, 17-4PH, F51
Bushing	SF-1, 304 / 316 + PTFE, 304 / 316 + Nitrided
Thrust Washer	304 + Graphite or PTFE
Packing	Graphite or PTFE

Note:
 ≤6" operating by the Lever
 Face-to-Face dimension: API 609 & MSS SP-68
 Flanged End: ASME B16.5 & ASME B16.47
 For other ends, please state in the order.

Note: for other body and internal parts material, we can produce according to customer's specification or request

Dimensions & Weights

NPS(in)	L(mm)	L1(mm)	H1(mm)	H(mm)	D0(mm)	L0(mm)	WT(Kg)		
							Wafer	Lug	Flange(Short Pattern)
2	43	108	110	135	-	150	10	11	20
3	48	114	125	155	-	180	11	13	29
4	54	127	147	162	-	200	13	16	33
6	57	140	166	240	-	300	26	28	74
8	64	152	215	375	180	-	36	43	86
10	71	165	238	396	180	-	53	64	142
12	81	178	283	446	180	-	74	86	167
14	92	190	302	472	315	-	110	127	218
16	102	216	338	555	350	-	138	159	275
18	114	222	381	605	400	-	180	211	315
20	127	229	408	638	480	-	196	225	395
24	154	267	495	738	480	-	400	462	580
28	165	292	561	976	480	-	560	655	657
30	190	318	590	1016	610	-	685	812	717
32	190	318	650	1160	610	-	726	868	880
36	203	330	700	1205	480	-	920	1056	1042
40	216	410	750	1294	480	-	1283	1470	1760
42	229	410	780	1350	480	-	1488	1723	1820
48	254	470	892	1523	480	-	1645	1895	2660

Class 300 Triple eccentric, metal to metal seat, wafer or flanged ends

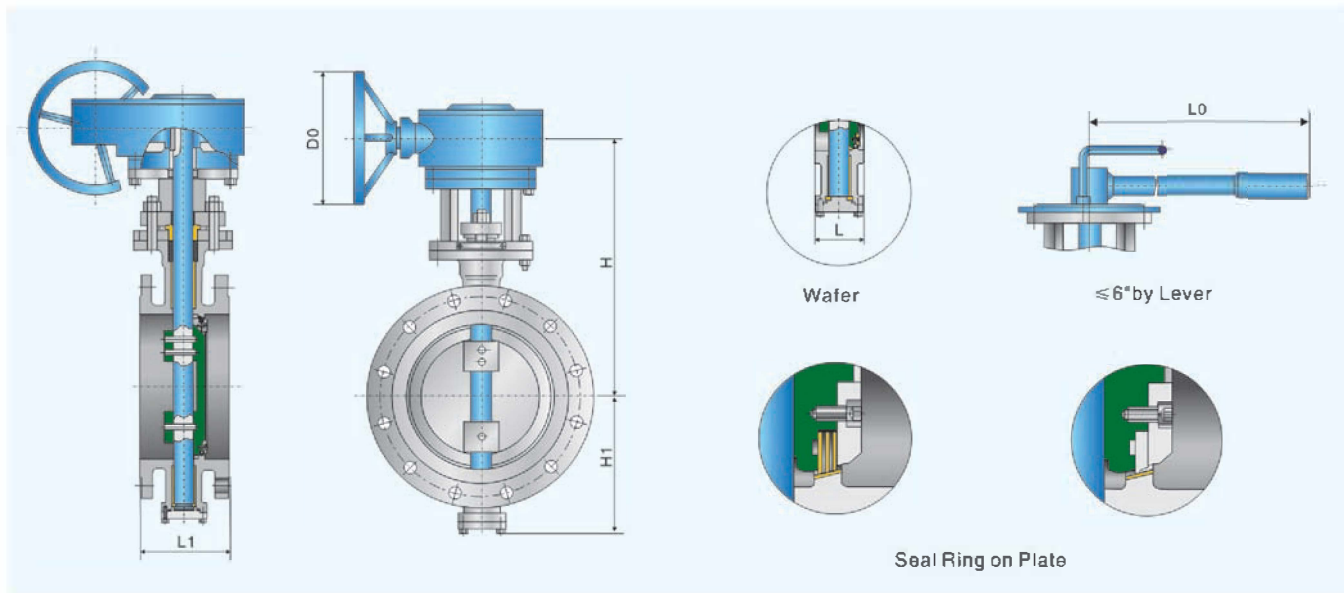

■ Main Parts and Materials

Parts	Material
Body	WCB, LCB, LCC, CF8, CF8M, CF3, CF3M
Seal Ring	304 / 316 / S31803 + Graphite / PTFE Laminated
Disc	WCB, LCB, LCC, CF8, CF8M, CF3, CF3M
Seal Surface	Cr13, 304, 316, Stellite or Integral on body
Stem	F6a, F304, 17-4PH, F51
Bushing	SF-1, 304 / 316 + PTFE, 304 / 316 + Nitrided
Thrust Washer	304 + Graphite or PTFE
Packing	Graphite or PTFE

Note:

≤6° operating by the Lever
Face-to-Face dimension: API 609 & MSS SP-68
Flanged End: ASME B16.5 & ASME B16.47
For other ends, please state in the order.

Note: for other body and internal parts material, we can produce according to customer's specification or request

■ Dimensions & Weights

NPS(in)	L(mm)	L1(mm)	H1(mm)	H(mm)	D0(mm)	L0(mm)	WT(Kg)		
							Wafer	Lug	Flange(Short Pattern)
3	48	180	125	155	-	180	13	15	29
4	54	190	147	162	-	200	18	21	35
6	59	210	166	240	-	300	29	33	81
8	73	230	215	375	180	-	38	42	94
10	83	250	238	396	180	-	58	63	156
12	92	270	283	446	180	-	91	86	183
14	117	290	302	472	315	-	121	131	239
16	133	310	338	555	350	-	153	165	302
18	149	330	381	605	400	-	197	211	346
20	159	350	408	638	480	-	215	238	434
24	181	390	495	738	480	-	443	465	638

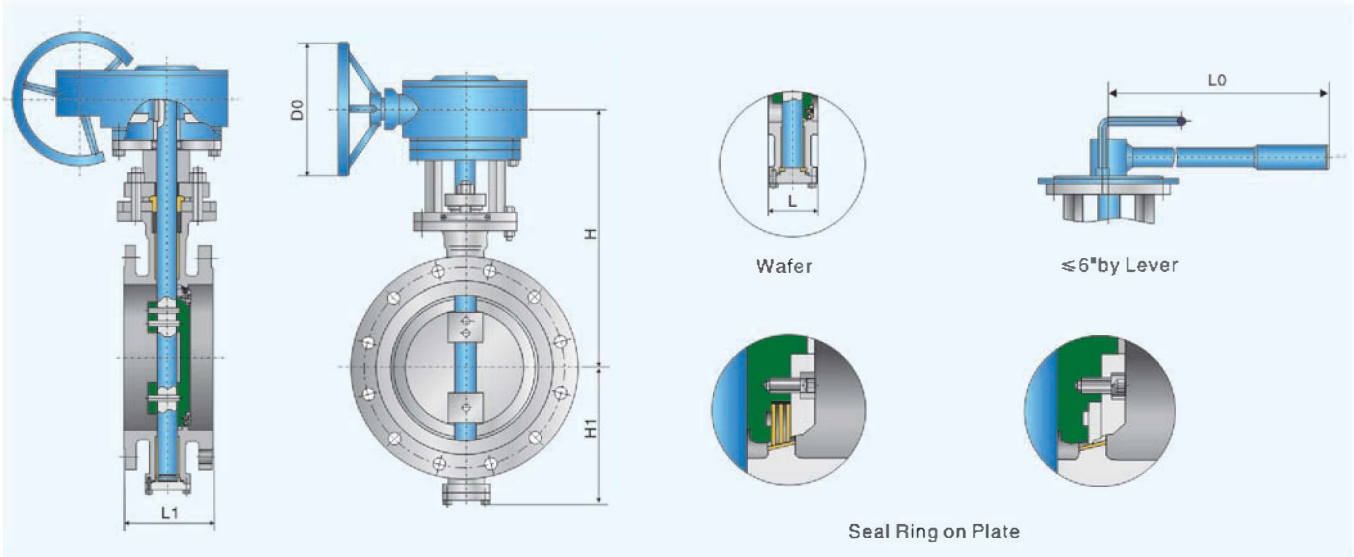

Main Parts and Materials

Parts	Material
Body	WCB, LCB, LCC, CF8, CF8M, CF3, CF3M
Seal Ring	304 / 316 / S31803 + Graphite / PTFE Laminated
Disc	WCB, LCB, LCC, CF8, CF8M, CF3, CF3M
Seal Surface	Cr13, 304, 316, Stellite or Integral on body
Stem	F6a, F304, 17-4PH, F51
Bushing	SF-1, 304 / 316 + PTFE, 304 / 316 + Nitrided
Thrust Washer	304 + Graphite or PTFE
Packing	Graphite or PTFE

Note:

≤6" operating by the Lever

Face-to-Face dimension: API 609 & MSS SP-68

Flanged End: ASME B16.5 & ASME B16.47

For other ends, please state in the order.

Note: for other body and internal parts material, we can produce according to customer's specification or request

Dimensions & Weights

NPS(in)	L(mm)	L1(mm)	H1(mm)	H(mm)	D0(mm)	L0(mm)	WT(Kg)		
							Wafer	Lug	Flange(Short Pattern)
3	180	54	170	414	-	250	25	28	56
4	190	64	185	447	-	300	39	42	86
5	200	78	205	480	-	300	65	72	110
6	210	78	216	495	315	-	93	98	143
8	230	102	265	536	406	-	135	165	235
10	250	117	315	641	406	-	242	284	366
12	270	140	362	727	508	-	267	394	487
14	290	155	390	757	508	-	448	508	655
16	310	178	440	825	610	-	505	599	855
18	330	200	460	840	762	-	642	856	992
20	350	216	526	978	812	-	800	1114	1390
24	390	232	623	1070	812	-	1305	1704	1910

Class 900 Triple eccentric, metal to metal seat, wafer or flanged ends

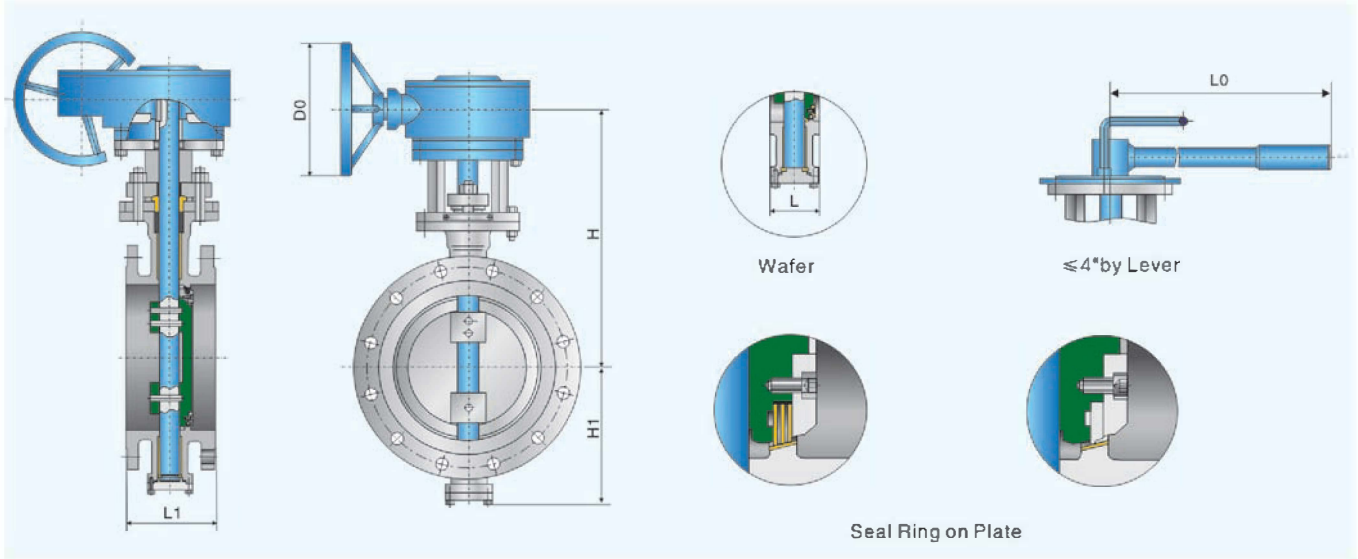

Main Parts and Materials

Parts	Material
Body	WCB, LCB, LCC, CF8, CF8M, CF3, CF3M
Seal Ring	304 / 316 / S31803 + Graphite / PTFE Laminated
Disc	WCB, LCB, LCC, CF8, CF8M, CF3, CF3M
Seal Surface	Cr13, 304, 316, Stellite or Integral on body
Stem	F6a, F304, 17-4PH, F51
Bushing	SF-1, 304 / 316 + PTFE, 304 / 316 + Nitrided
Thrust Washer	304 + Graphite or PTFE
Packing	Graphite or PTFE

Note:

≤4" operating by the Lever

Face-to-Face dimension: API 609 & MSS SP-68

Flanged End: ASME B16.5 & ASME B16.47

For other ends, please state in the order.

Note: for other body and internal parts material, we can produce according to customer's specification or request

Dimensions & Weights

NPS(in)	L(mm)	L1(mm)	H1(mm)	H(mm)	D0(mm)	L0(mm)	WT(Kg)		
							Wafer	Lug	Flange(Short Pattern)
4	229	92	197	459	-	300	-	-	-
5	267	102	220	495	508	-	-	-	-
6	267	102	236	515	508	-	-	125	180
8	292	140	290	561	610	-	-	260	295
10	330	155	343	669	711	-	-	327	460
12	356	178	394	759	762	-	-	490	630
14	381	290	428	795	812	-	-	670	810
16	406	310	482	867	812	-	-	888	1025
18	432	330	505	885	812	-	-	1053	1290
20	457	350	576	1028	914	-	-	1441	1795
24	508	350	678	1125	914	-	-	2238	2995

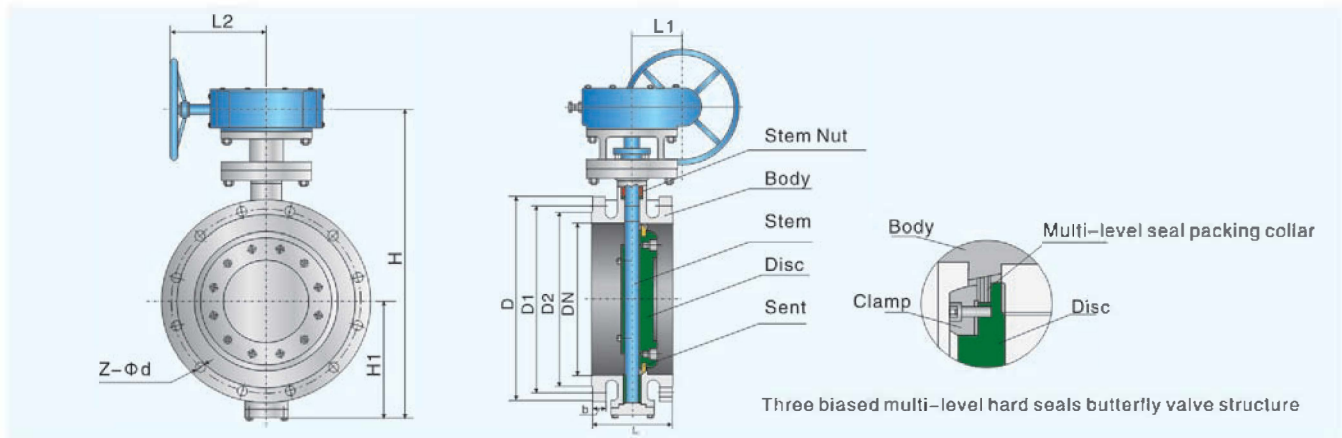

Features and usage

Triple offset multi-level metal hard seal butterfly valve series, is the long life which the our company newly develops, not divulges, the energy conservation butterfly valve. The product conforms to national standard DIN 3354 –1982 (metal hard to seal reed valve), EN 12266. 1 –2003 (general valve pressure test) the standard and the valve other correlation standards stipulations, unifies the domestic and foreign advanced technologies, uses the three dimensional eccentric principle design, the seal packing collar uses hard soft seals the concurrently multi-level structure, is suitable to the medium temperature $\leq 65^{\circ}\text{C}$ metallurgy, the electric power, the petroleum chemical industry, the air, the coal gas, as well as for medium pipeline on and so on the draining water makes the adjustment current capacity and the interruption fluid, the sealing property is reliable, is the general reed valve presses, center high temperature domain extending to the center with the development.

In this structure foundation, may use the teflon to substitute the multi-level seal packing collar, forms the new generation of three biased four fluorine seals reed valve, widespread application in temperature $\leq 200^{\circ}\text{C}$ corrosive medium environment.

Features

1. The valve disc board seal packing collar for hard is soft double-decked, has the hard soft seal dual seal merit, regardless of in the low temperature or under the high temperature operating mode, has the fine sealing property.
2. Uses three eccentric structures, the valve seat and the butterfly board nearly no friction, has the pass tighter sealing property, achieved zero leakage.
3. Opens shuts the moment of force slightly, the operation nimble, the vigor energy conservation, the service life is longer.
4. Thermostable, bears the high pressure, the anti-corrosive applicable scope is broad.
5. The new generation of three biased four fluorine seals reed valve concurrently has had three biased seals structure and the soft seal merit, the sealing property more reliable, the applicable scope broader, the service life is longer.
6. Electrically operated, the pneumatics uses the domestic and foreign famous products, the performance is more reliable (may assign by user).

Material for main parts

Parts name	Parts material
Body	Carbon steel, Stainless, Cr-Mo steel, Alloy steel
Disc	Carbon steel, Stainless, Cr-Mo steel, Alloy steel
Seal ring	316 stainless steel+flexible graphite, Teflon
Stem	Stainless steel, Cr-Mo steel
Packing	Flexible graphite, Teflon
Note: WCB, WC6, WC9, ZG1Cr5Mo, ZG20GrMo, CF8, CF8M, CF3, CF3M	

Applicable standard

Design: DIN 3354, EN593
 Face to face: EN558-1, ISO 5257-13&14 Series
 Flange end: EN1092-1
 Leakage Class: Class VI
 Inspection & Test: ISO 5208, EN 12266.1

Main technical parameter

Nominal diameter	DN(mm)	100~3000				100~600
		0.6	1.0	1.6	2.5	
Nominal pressure	PN(Mpa)	0.6	1.0	1.6	2.5	4.0
Test pressure	shell structural testing	0.9	1.5	2.4	3.75	6.0
	Seal test	0.66	1.1	1.76	2.75	4.0
	Air test	0.6	0.6	0.6	0.6	0.6
Applicable medium	Water, steam, oil, acids, corrosive medium and so on and dust pellet					
Applicable temperature	$-29^{\circ}\text{C} \leq \text{Carbon steel} \leq 425^{\circ}\text{C}$, $-40^{\circ}\text{C} \leq \text{Stainless steel} \leq 600^{\circ}\text{C}$, $\text{Cr-Mo steel} \leq 650^{\circ}\text{C}$					
Actuation form	Handle, worm gear, electrically operated, air operated					

DIN metal-to-metal / PTFE gear operated flange type butterfly valve



■ D343_F-PN10/10K(DN50-3000) Main dimensions

DN(mm) Nominal diameter	Main contour and connection size									
	L	D	D1	D2	b	H	H1	L1	L2	Z-Φd
50	108	165	125	102	18	320	85	40	130	4-18
65	112	185	145	122	18	370	90	40	130	4-18
80	114	200	160	138	20	370	100	40	130	8-18
100	127	220	180	158	20	370	125	48	145	8-18
125	140	250	210	188	22	420	135	70	175	8-18
150	140	285	240	212	22	505	172	70	175	8-22
200	152	340	295	268	24	610	240	90	200	8-22
250	165	395	350	320	26	665	265	90	200	12-22
300	178	445	400	370	26	755	295	125	280	12-22
350	190	505	460	430	26	860	330	125	280	16-22
400	216	565	515	482	26	890	370	125	280	16-26
450	222	615	565	532	28	966	395	130	280	20-26
500	229	670	620	585	28	1040	430	130	280	20-26
600	267	780	725	685	34	1285	490	175	365	20-30
700	292	895	840	800	34	1395	545	175	365	24-30
800	318	1015	950	905	36	1560	615	225	440	24-33
900	330	1115	1050	1005	38	1700	700	225	440	28-33
1000	410	1230	1160	1110	38	1865	715	290	490	28-36
1200	470	1455	1380	1330	44	2125	865	290	490	32-39
1400	530	1675	1590	1535	48	2340	950	290	490	36-42
1600	600	1915	1820	1760	52	2580	1070	410	600	40-48
1800	670	2115	2020	1960	56	2880	1200	500	600	44-48
2000	760	2235	2230	2170	60	3200	1350	500	800	48-48
2200	590	2500	2440	2370	64	3750	1350			52-56
2400	650	2760	2650	2570	65	4350	1550			56-56
2600	700	2960	2850	2780	67	4600	1650			60-56
2800	760	3180	3070	3000	68	4900	1760			64-56
3000	810	3405	3290	3210	68	5300	1980			68-62

■ D343_F-PN16(DN50-2000) Main dimensions

DN(mm) Nominal diameter	Main contour and connection size									
	L	D	D1	D2	b	H	H1	L1	L2	Z-Φd
50	108	165	125	102	20	320	85	40	130	4-18
65	112	185	145	122	20	320	90	40	130	4-18
80	114	200	160	138	20	370	100	40	130	8-18
100	127	220	180	158	22	370	125	48	145	8-18
125	140	250	210	188	22	420	135	70	175	8-18
150	140	285	240	212	24	505	172	70	175	8-22
200	152	340	295	268	24	610	240	90	200	12-22
250	165	405	355	320	26	665	265	90	200	12-26
300	178	460	410	378	28	755	295	125	280	12-26
350	190	520	470	438	30	860	330	125	280	16-26
400	216	580	525	490	32	890	370	125	280	16-30
450	222	640	585	550	34	966	395	130	280	20-30
500	229	715	650	610	36	1040	430	130	280	20-33
600	267	840	770	725	40	1285	490	175	365	20-36
700	292	910	840	795	42	1395	545	175	365	24-36
800	318	1025	950	900	42	1560	615	225	440	24-39
900	330	1125	1050	1000	44	1700	700	225	440	28-39
1000	410	1255	1170	1115	46	1865	715	290	490	28-42
1200	470	1485	1390	1330	52	2125	865	290	490	32-48
1400	530	1685	1590	1530	58	2340	950	290	490	36-48
1600	600	1930	1820	1750	64	2580	1070	410	600	40-56
1800	670	2130	2020	1950	68	2880	1200	500	600	44-56
2000	760	2345	2230	2150	70	3200	1350	500	800	48-64

■ D343^H_F-PN25/20K(DN50-2000) Main dimensions

DN(mm) Nominal diameter	Main contour and connection size									
	L	D	D1	D2	b	H	H1	L1	L2	Z-Φd
50	108	165	125	102	18	320	85	40	130	4-18
65	112	185	145	122	22	320	90	40	130	4-18
80	114	200	160	138	24	370	100	40	130	8-18
100	127	235	190	162	24	370	125	48	145	8-22
125	140	270	220	188	26	420	135	70	175	8-26
150	140	300	250	218	28	505	172	70	175	8-26
200	152	360	310	278	30	610	240	90	200	12-26
250	165	425	370	335	32	665	265	90	200	12-30
300	178	485	430	395	34	755	295	125	280	16-30
350	190	555	490	450	38	860	330	125	280	16-33
400	216	620	550	505	40	890	370	125	280	16-36
450	222	670	600	560	42	966	395	130	280	20-36
500	229	730	660	615	44	1040	430	130	280	20-36
600	267	845	770	720	46	1285	490	175	365	20-39
700	292	960	875	820	50	1395	545	175	365	24-42
800	318	1085	990	930	54	1560	615	225	440	24-48
900	330	1185	1090	1030	58	1700	700	225	440	28-48
1000	410	1320	1210	1140	62	1865	715	290	490	28-56
1200	470	1530	1420	1350	70	2125	865	290	490	32-56
1400	530	1755	1640	1560	76	2340	950	290	490	36-62
1600	600	1975	1860	1780	84	2580	1070	410	600	40-62
1800	670	2195	2070	1985	90	2880	1200	500	600	44-70
2000	760	2425	2300	2210	96	3200	1350	500	800	48-70

■ D343^H_F-PN40(DN50-600) Main dimensions

DN(mm) Nominal diameter	Main contour and connection size									
	L	D	D1	D2	b	H	H1	L1	L2	Z-Φd
50	108	165	125	102	18	320	110	40	130	4-18
65	112	185	145	122	22	320	110	40	130	8-18
80	114	200	160	138	24	370	120	40	130	8-18
100	190	235	190	162	24	370	142	160	223	8-22
125	200	270	220	188	26	420	157	160	223	8-26
150	210	300	250	218	28	505	192	195	130	8-26
200	230	375	320	285	34	620	255	195	130	12-30
250	250	450	385	345	38	680	270	195	300	12-33
300	270	515	450	410	42	770	350	250	635	16-33
350	290	580	510	465	46	885	375	250	635	16-36
400	310	660	585	535	50	910	420	250	635	16-39
450	330	685	610	560	57	980	440	250	635	20-39
500	350	755	670	615	57	1060	500	250	635	20-42
600	390	890	795	735	72	1315	550	295	680	20-48

DIN metal-to-metal / PTFE gear operated wafer type butterfly valve

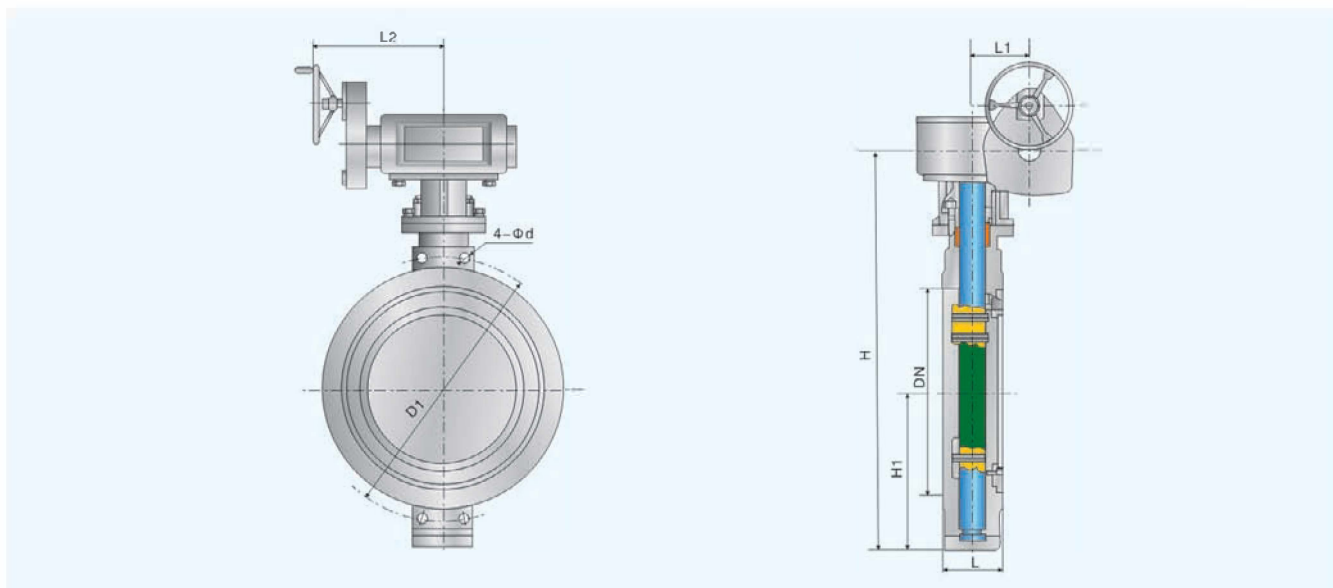

■ D373^H_F-PN6、10/10K(DN50-2000) Main dimensions

DN(mm) Nominal diameter	Main contour and connection size								
	L	H	H1	L1	L2	PN0.6MPa		PN1.0MPa	
						D1	4-Φd	D1	4-Φd
50	43	250	80	48	145	110	4-14	125	4-18
65	46	265	95	48	145	130	4-14	145	4-18
80	49	275	100	48	145	150	4-18	160	4-18
100	56	370	125	48	145	170	4-18	180	4-18
125	64	420	135	70	175	200	4-18	210	4-18
150	70	505	172	70	175	225	4-18	240	4-22
200	71	610	240	90	200	280	4-18	295	4-22
250	76	665	265	90	200	335	4-18	350	4-22
300	83	755	295	125	280	395	4-22	400	4-22
350	92	860	330	125	280	445	4-22	460	4-22
400	102	890	370	125	280	495	4-22	515	4-26
450	114	966	395	130	280	550	4-22	565	4-26
500	127	1040	430	130	280	600	4-22	620	4-26
600	154	1285	490	175	365	705	4-26	725	4-30
700	165	1395	545	175	365	810	4-26	840	4-30
800	190	1560	615	225	440	920	4-30	950	4-33
900	203	1700	700	225	440	1020	4-30	1050	4-33
1000	216	1865	715	290	490	1120	4-30	1160	4-36
1200	254	2125	865	290	490	1340	4-33	1380	4-39
1400	279	2340	950	290	490	1560	4-36	1590	4-42
1600	318	2580	1070	410	600	1760	4-36	1820	4-48
1800	356	2880	1200	500	600	1970	4-39	2020	4-48
2000	406	3200	1350	500	800	2180	4-42	2230	4-48

■ D373^H/_F-16²⁵(DN50-2000) Main dimensions

DN(mm) Nominal diameter	Main contour and connection size								
	L	H	H1	L1	L2	PN1.6MPa		PN2.5MPa	
						D1	4-Φd	D1	4-Φd
50	43	250	80	48	145	125	4-18	125	4-18
65	46	265	95	48	145	145	4-18	145	4-18
80	49	275	100	48	145	160	4-18	160	4-18
100	56	370	125	48	145	180	4-18	190	4-22
125	64	420	135	70	175	210	4-18	220	4-26
150	70	505	172	70	175	240	4-22	250	4-26
200	71	610	240	90	200	295	4-22	310	4-26
250	76	665	265	90	200	355	4-26	370	4-30
300	83	755	295	125	280	410	4-26	430	4-30
350	92	860	330	125	280	470	4-26	490	4-33
400	102	890	370	125	280	525	4-30	550	4-36
450	114	966	395	130	280	585	4-30	600	4-36
500	127	1040	430	130	280	650	4-33	660	4-36
600	154	1285	490	175	365	770	4-36	770	4-39
700	165	1395	545	175	365	840	4-36	875	4-42
800	190	1560	615	225	440	950	4-39	990	4-48
900	203	1700	700	225	440	1050	4-39	1090	4-48
1000	216	1865	715	290	490	1170	4-42	1210	4-55
1200	254	2125	865	290	490	1390	4-48	1420	4-55
1400	279	2340	950	290	490	1590	4-48	1640	4-60
1600	318	2580	1070	410	600	1820	4-56	1860	4-62
1800	356	2880	1200	500	600	2020	4-56	2070	4-70
2000	406	3200	1350	500	800	2230	4-62	2300	4-70

■ D373^H/_F-PN40(DN100-DN600) Main dimensions

DN(mm) Nominal diameter	Main contour and connection size							
	L	D1	H	H1	L1	L2	4-Φd	
50	43	125	320	110	130	180	4-18	
65	46	145	320	110	130	180	4-18	
80	64	160	320	120	140	205	4-18	
100	64	190	370	142	160	223	4-22	
125	70	220	420	157	160	223	4-26	
150	76	250	505	192	195	230	4-26	
200	89	320	620	255	195	230	4-30	
250	114	385	680	270	195	300	4-33	
300	114	450	770	350	250	635	4-33	
350	127	510	885	375	250	635	4-36	
400	140	585	910	420	250	635	4-39	
450	152	610	980	440	250	635	4-39	
500	152	670	1060	500	250	635	4-42	
600	178	795	1315	550	295	680	4-48	